

# PF22

## TABLETOP PERISTALTIC FILLING MACHINE

- No cross contamination
- Accuracy +/-0.5%
- 5 to 5,000 ml
- Drip-free
- Change of product in 1 minute



WORLD LEADERS IN ASEPTIC PERISTALTIC FILLING



## PF22 TECHNICAL SPECIFICATIONS

PF22 – capacity diagram (based on water)

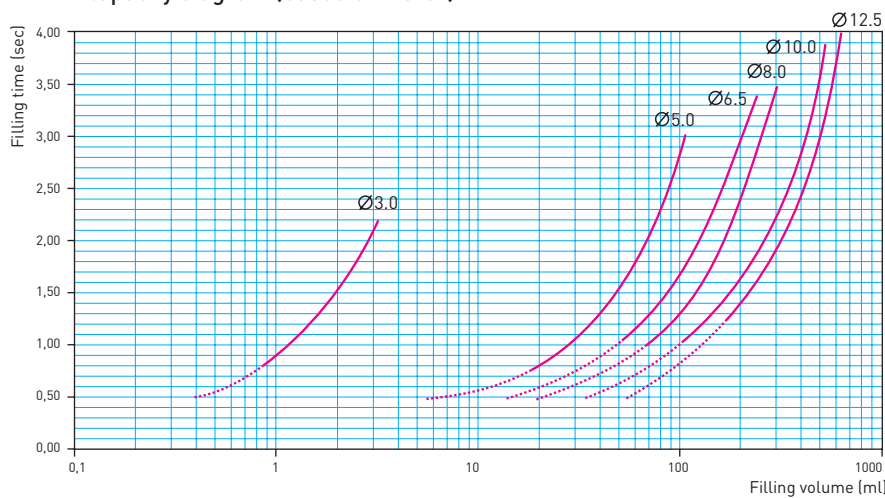

The peristaltic filling principle is the fastest growing in the pharmaceutical industry due to established advantages such as sterility, guarantee against cross contamination and easy cleaning. These are achieved by the fact that the product is in contact only with the medically approved tubing and filling nozzle.

PF22 is an extremely flexible liquid filling machine, which can fill volumes from 5 ml to more than 5,000 ml with an accuracy better than +/-0.5%. This outstanding flexibility and accuracy is achieved without having to change anything but the dimension of the tubing in use.

When using PF22, filling of all kinds of vials, bottles, test tubes and other kinds of containers is obtained by loading the tube and typing in the filling parameters on the key pad - all carried out in less than 3 minutes.

As PF22 maintains a closed fluid path from the bulk product container to the end of the filling nozzle, substitution of this fluid path means that PF22 is instantly cleaned and ready for the next operation.

PF22 is equipped with electrical interface ports, which allow use of a foot switch or integration of automatic

bottle handling systems. Furthermore, PF22 also has an RS232 port for connection to a printer for real-time production documentation.

PF22 is designed for use in cleanroom environments for production complying with cGMP and its outstanding performance and reliability is demonstrated by the many hundreds of installations world-wide. PF22 is a part of the product program, which has proved Watson-Marlow Flexicon to be the world's leading manufacturer of peristaltic filling systems.

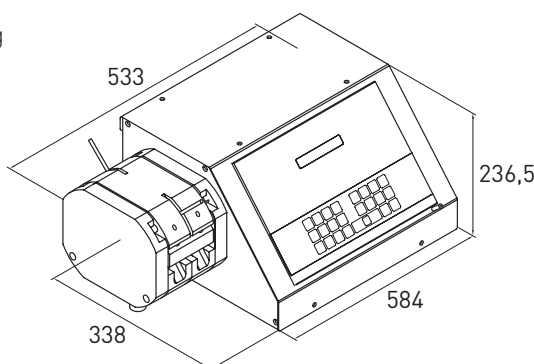

**Filling volume:**  
 5 ml to more than 5,000 ml

**Accuracy:**  
 Better than +/-0.5%

**Human machine interface:**  
 Communication with user through a membrane-type keyboard and an LCD display

**Pump head:**  
 Peristaltic quick-change head in anodised aluminium and 12 offset rollers in AISI304 stainless steel

**Tubes:**  
 Flexicon silicone tubes with a 2.5 to 3.5 mm wall. The tubes are approved for pharmaceutical use, according to FDA and USP standards. The tubes are available in other materials as well

**Tube sizes:**  
 3.0 - 5.0 - 6.5 - 8.0 - 10.0 - 12.5 mm i.d.

**Mains:**  
 110/230 VAC earthed, 50/60 Hz

**Power consumption:**  
 Max. 350 W

**Cabinet:**  
 Anodised aluminium with integrated filling stand in stainless steel

**Ingress protection:**  
 IP31

**Weight:**  
 25 kg

**Interface:**  
 RS-232 for printer  
 1 x (5-50 VDC) input for start  
 1 x open collector output for status

**Accessories:**  
 Filling nozzles, tubes, filling stand, pneumatic diving nozzle system, foot switch, printer, etc.