

825 series hygienic pump

800 series

Watson-Marlow Bredel

FEATURES

- Flow rates from 162 litre/hour to 2,060 litre/hour (0.33 l/rev)
- Clean-in-place and steam-in-place sterilisation at full velocity with no bypass required
- Bioprene tube to USP Class VI and hygienic stainless steel connectors certificated to 3.1.B BS/EN 10204.
- Bioprene tubing available in two hardnesses for pressures up to 2 bar and 3.5 bar.
- Pumpheads to accept B5 output flange-mounted gear motors in a range of single and three phase fixed and electronic variable speeds
- Hinged door with only two captive bolts makes tube inspection and change extremely simple and safe
- ATEX version available
- Options include STA-PURE tubing for pressures up to 3.5 Bar and a wide variety of connectors

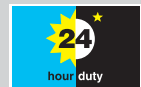

PERFORMANCE

Speed (rpm)	Flow rate (litre/hour)	Fitted Motor Power (kilowatts)	Speed (rpm)	Flow rate (litre/hour)	Fitted Motor Power (kilowatts)
8	162	0.37	40	796	0.55
10	196	0.37	47	933	0.75
13	260	0.55	53	1050	0.75
17	327	0.55	59	1169	0.75
21	412	0.55	67	1327	0.75
26	507	0.55	74	1474	1.1
28	563	0.55	84	1672	1.1
33	658	0.55	90	1787	1.1
36	721	0.55	104	2060	1.1

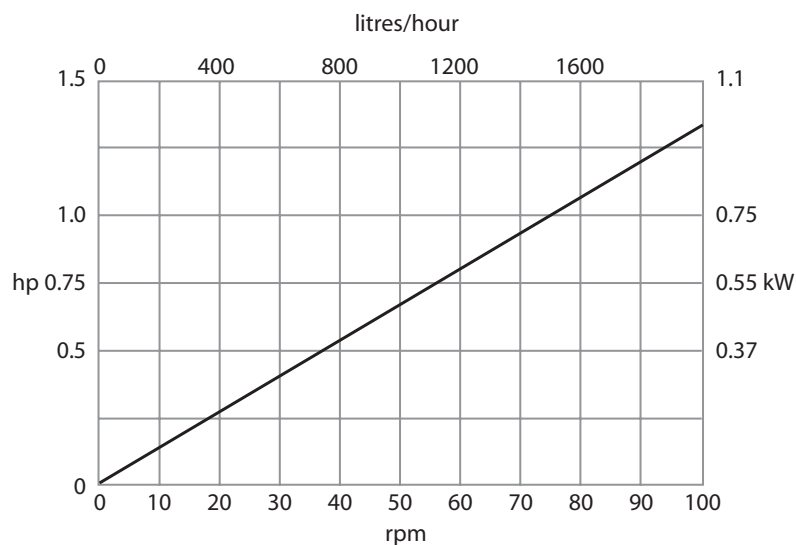

For variable speed units and other build options, please contact your local representative, or the Watson-Marlow Bredel Applications Engineering department.

DRAWINGS

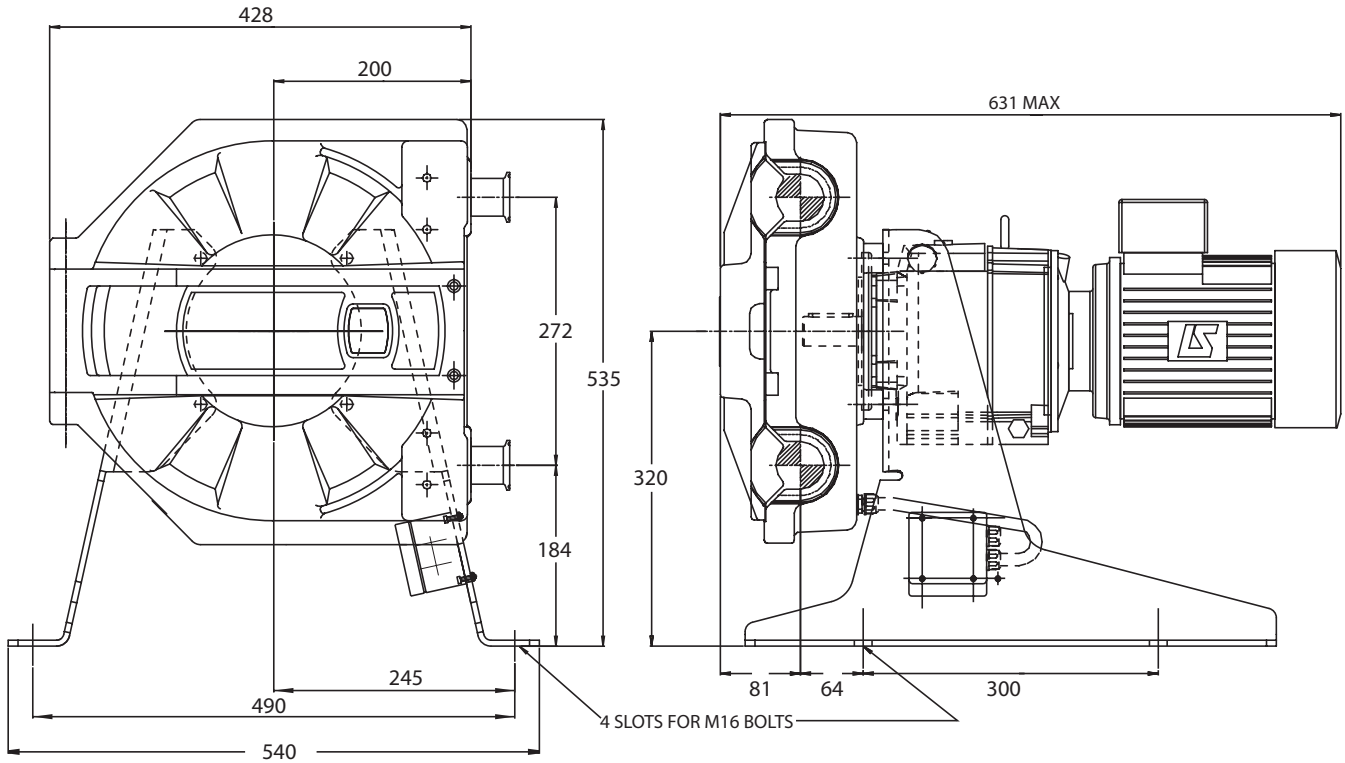

SPECIFICATIONS

Environment Temperature	5C to 40C (40°F to 104°F)
Fluid Temperature	0 C to 80 C (-32°F to 175°F)
Max Pressure	3.5 Bar
Pump weight	Dependant upon drive. Nominally 85kgs
Noise	< 75dB(A) at 1m

MATERIALS OF CONSTRUCTION

Component	Material
Pumphead body	Aluminum alloy with epoxy polyester powder coat finish
Pumphead door	Aluminum alloy with epoxy polyester powder coat finish
Pumphead rotor hub	Aluminum alloy with epoxy polyester powder coat finish
Rotor rollers	Stainless steel 316
Support frame	Stainless steel 304
Door fixings	Stainless steel
Motor fixings	Zinc plated high tensile steel bolts, stainless steel nuts and washers
Frame fixings	Stainless steel

All flow rates shown were obtained pumping water at 20C (68F) with zero suction and delivery heads. Watson-Marlow, Bioprene and Marprene are trademarks of Watson-Marlow Limited. Disclaimer: The information contained in this document is believed to be correct but Watson-Marlow Limited accepts no liability for any errors it contains, and reserves the right to alter specifications without notice. LoadSure is a trademark of Watson-Marlow Limited. ® Chem-Sure and ® STA-PURE are registered trademarks of W.L. Gore & Associates Inc. Pumpsil is a trademark of Watson-Marlow Limited. Please state the product code when ordering pumps and tubing.



Watson-Marlow-Bredel Pumps
 Falmouth, Cornwall England TR11 4RU
 Tel: +44 (0)1326 370370 Fax: +44 (0)1326 376009
 www.watson-marlow.com info@watson-marlow.co.uk