

840 series hygienic pump

800 series

Watson-Marlow Bredel

FEATURES

- Flow rates up to 2,289 gph (144 L/min) at 50 psi (3.5 bar) continuous pressure
- Clean-in-place and steam-in-place sterilization at full velocity with no bypass required
- Ideal for viscous or shear sensitive products
- Bioprene or STA-PURE tube certified to USP Class VI and FDA approved with hygienic stainless steel connectors
- Bioprene tubing available in two hardnesses for pressures up to 30 psi (2 bar) and 50 psi (3.5 bar). STA-PURE tubing is rated for pressures up to 50 psi (3.5 bar)
- Pumpheads to accept B5 output flange-mounted gear motors in a range of single and three phase fixed and electronic variable speeds
- Hinged door with only two captive bolts makes tube inspection and change extremely simple and safe
- Explosion proof version available
- Options include stainless steel pushbar and swivel caster set for mobile applications and a wide variety of connectors



PERFORMANCE

Speed (rpm)	Flow rate (gph)	Flow rate (L/min)	Fitted Motor Power (hp)
29	611	39	1.5
54	1138	72	2.0
83	1750	110	3.0
102	2150	136	5.0

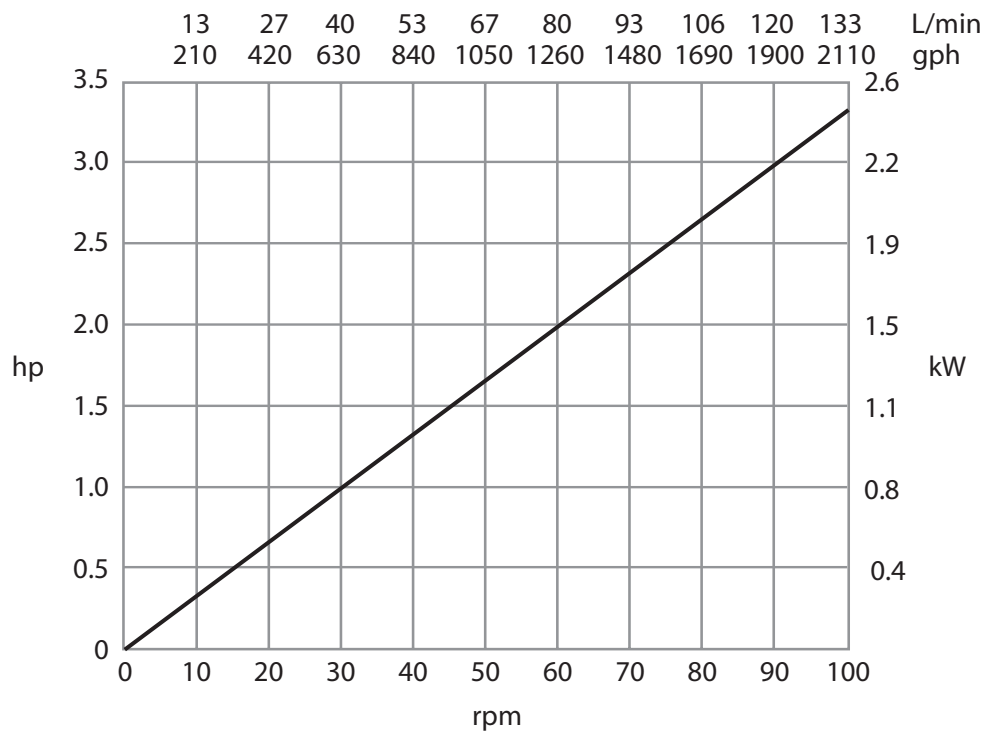

For variable speed units and other gearing or build options, please contact your local representative, or the Watson-Marlow Bredel Applications Engineering department.

DRAWINGS

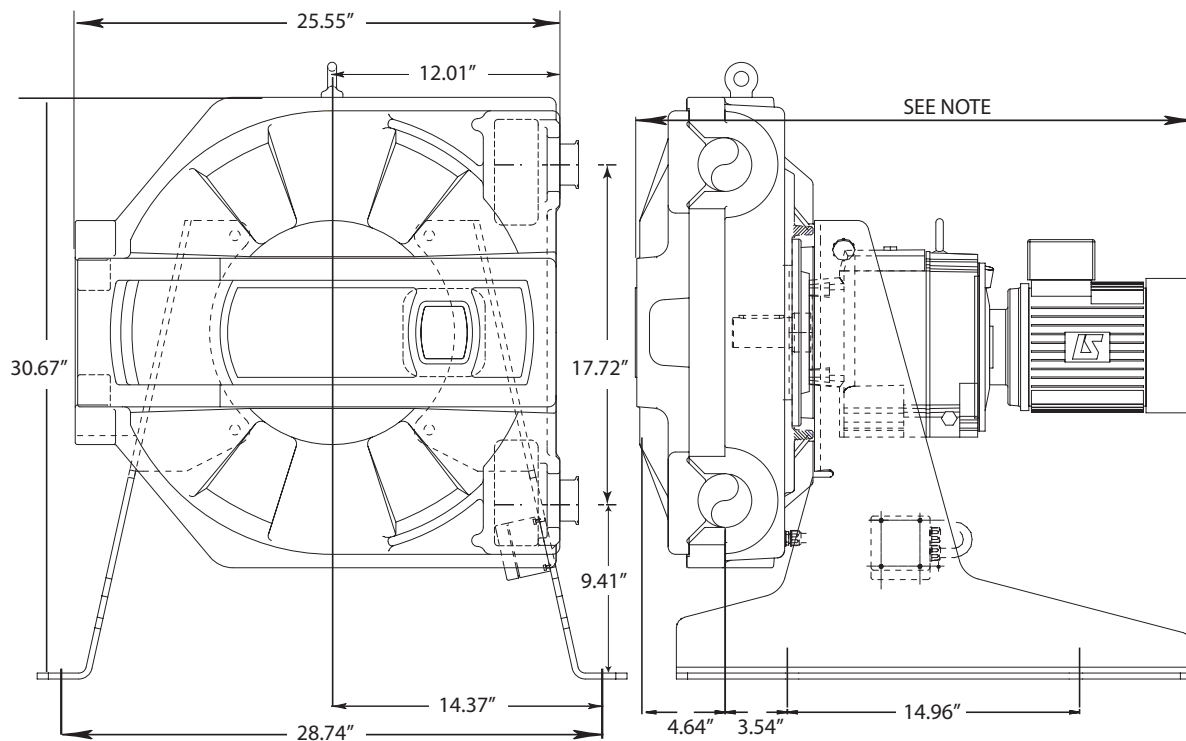

Length dependant on selection of gearbox and motor

SPECIFICATIONS

Environment Temperature	40°F to 104°F
Fluid Temperature	-32°F to 175°F
Max Operating Speed	109 rpm
Max Pressure	50 psi continuous (3.5 Bar)
Suction Pressure	Up to 28 ft water
Pump weight	Dependant upon drive. Nominally 525 lbs
Control ratio	Dependant upon VFD selection
Noise	< 75dB(A) at 1m
Supply	230/460/575 3ph 60Hz, 115/230 1ph 60Hz
Door Switch	50 Watt, 240VAC (not suitable for XP environments)
Power	Up to 5 hp

MATERIALS OF CONSTRUCTION

Component	Material
Pumphead body	Aluminum alloy with epoxy polyester powder coat finish
Pumphead door	Aluminum alloy with epoxy polyester powder coat finish
Pumphead rotor hub	Aluminum alloy with epoxy polyester powder coat finish
Rotor rollers	Stainless steel 316
Support frame	Stainless steel 304
Door fixings	Stainless steel 304
Motor fixings	Zinc plated high tensile steel bolts, stainless steel nuts and washers
Frame fixings	Stainless steel 304

ORDER INFORMATION

Element and Connector product codes			
Description	Sanitary	Description	Partcode
Bioprene TM hose	088.0400.E0M	1" Tri-clamp, 316SS	089.0400.00T
Bioprene TH hose	088.0400.E0H	1" Tri-clamp, PVDF	089.0400.00K
Sta-pure hose	089.0400.000	1" Male Cam & Groove, 316SS	089.0400.00Q

All flow rates shown were obtained pumping water at 68°F with zero suction and delivery heads. Watson-Marlow, Bioprene and Marprene are trademarks of Watson-Marlow Limited. Disclaimer: The information contained in this document is believed to be correct but Watson-Marlow Limited accepts no liability for any errors it contains, and reserves the right to alter specifications without notice. LoadSure is a trademark of Watson-Marlow Limited. © Chem-Sure and © STA-PURE are registered trademarks of W.L. Gore & Associates Inc. Please state the product code when ordering pumps and tubing.



Watson-Marlow Bredel Pumps
37 Upton Technology Park
Wilmington, MA 01887
Tel: 800 282 8823 Fax: 978 658 0041
www.watson-marlow.com support@watson-marlow.com